

PROFILE

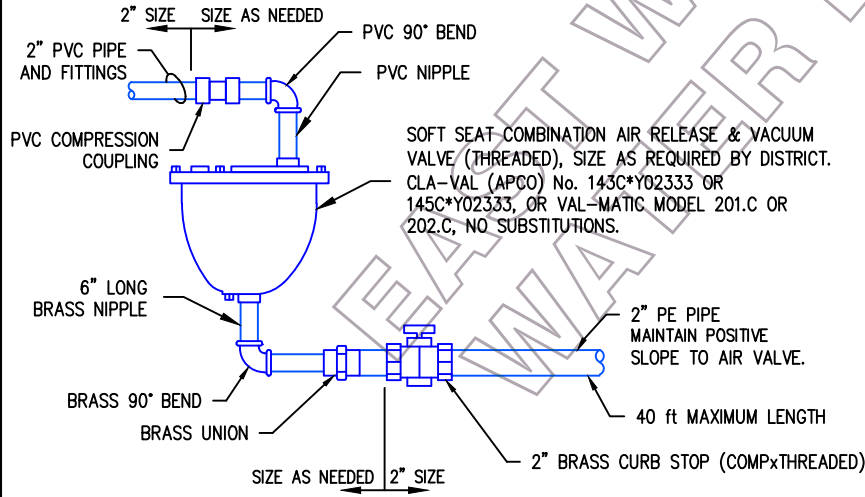

ENLARGEMENT

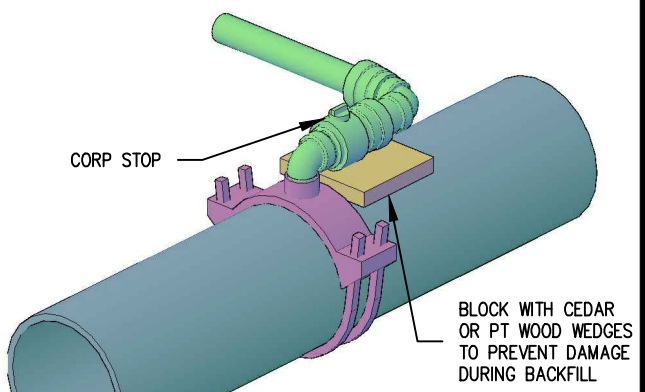

TAP SWING JOINT

1. AIR VALVE ASSEMBLIES SHALL BE INSTALLED AT EVERY HIGH POINT.
2. COMBINATION AIR RELEASE AND VACUUM VALVE SHALL BE A 1" SIZE FOR 6" OR 8" MAINS WHEN SPACED AT 1,500' MAX. ALL OTHER INSTALLATIONS SHALL BE 2" SIZE.
3. FOR 1" COMBINATION VALVE, INSTALL 2"x1" BRASS REDUCER BETWEEN CURB STOP AND UNION.
4. SEE DETAIL W-29 FOR VAULT INSTALLATION REQUIREMENTS.
5. ALL METAL FITTINGS TO BE DOMESTIC MADE. ALL PVC PIPE & FITTINGS TO BE SCHEDULE 40 MINIMUM.

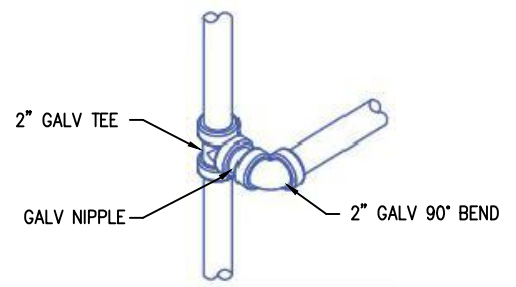

VENT SWING JOINT

**East Wenatchee
Water District**



WATER SYSTEM STANDARD DETAIL

**COMBINATION AIR
VALVE ASSEMBLY**